

M-6241-BE-LV & GE-LV Hot Melt Adhesive Sealant

Description

M-6241-BE-LV and GE-LV are low to mid range viscosity hot melt adhesive sealant designed to be used in the fabrication of automobile lamp assemblies. This series of sealant provides excellent bonding and sealing between Polycarbonate lenses and the housing of automobile lamps.

Typical Properties (Not a specification)

	<u>M-6241-BE-LV</u>	<u>M-6241-GE-LV</u>
Color	Black	Gray
Specific Gravity	0.96	0.96
Hardness, Shore A	25	25
Non-volatile Content (%) Min.	98.0	98.0
Viscosity at 190°C(cps)	40,000	40,000
Pot Life (in melting tank at 190°C-200°C) (hrs.)	72	72
Open Time (sec.) max.	90	90
Appearance	Free from foreign matter and uniform in color.	
Homogeneity	Homogeneous, less than 2 mm thickness of char.	

Typical Performance Properties

Bond Strength-Tensile Adhesion	(Channel/leg)
Substrate type	Polycarbonate/Polypropylene
Jaw separation rate	50mm/minute
Open Time	30 sec. @ 20°C
Bond Strength	Kgf/Test piece

Initial Results at various temperatures

@ -20°C	61
@ 20°C	16
@ 50°C	3.1
@ 80°C	1.0
40°Cwater x 120 hrs	18*



*Tested @ 20°C

103 Kuhlman Drive, Versailles Kentucky 40383, (859) 879-2855 Fax (859) 879-0574

The information contained herein is, to the best of our knowledge and belief, accurate. However, since the conditions of handling and of use are beyond our control, we make no guarantee of results and assume no liability for damages incurred by following these suggestions. Nothing contained herein is to be construed as recommendation for use in violation of any patents or of applicable laws or regulations.

Test Specimen

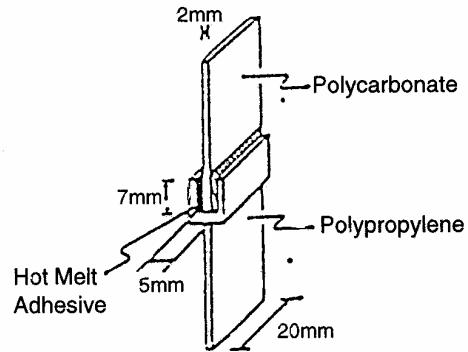

Application Information

Application should be by bulk or tank-type hot melt applicator equipment. The lens leg and the lamp housing must be mated within 30 seconds of the extrusion of the hot melt and held until the hot melt has hardened and the mated surfaces are immovable, the compression should be firm and even to achieve the most effective bond and seal.

Storage and Handling

M-6241-LV series adhesive sealants should be stored inside at room temperature and away from direct sunlight, water and any heat sources.

See Safety Precautions for safe handling instructions.

Shelf Life

One year after the date of manufacture, when stored at room temperature in the original, unopened container.

Safety Precautions

These products are for industrial use only. Observe standard hygienic practices in handling M-6241-LV series adhesive sealant, such as washing hands after use and before eating and smoking. Avoid skin contact with molten material. Consult the Material Safety Data Sheets and product label for additional safe handling and emergency information.

Availability

For your handling and storage convenience, the standard packaging for M-6241-LV series adhesive sealant is a 26-lb. corrugated carton, 33-lb. pail or 330-lb. drum.



103 Kuhlman Drive, Versailles Kentucky 40383, (859) 879-2855 Fax (859) 879-0574

The information contained herein is, to the best of our knowledge and belief, accurate. However, since the conditions of handling and of use are beyond our control, we make no guarantee of results and assume no liability for damages incurred by following these suggestions. Nothing contained herein is to be construed as recommendation for use in violation of any patents or of applicable laws or regulations.

